

# 145kV-170kV 40/50/63kA 2000-3000-4000A Dead Tank SF<sub>6</sub> Gas Circuit Breakers

Hitachi HVB, Inc.



## HS SERIES

### ■ Interrupter Features

SyncroPuff™ - True puffer design  
Pre-insertion resistors available

### ■ Mechanism

Spring/Spring gang-operated  
3 cycle fault interruption

### ■ Bushing Type

Porcelain or composite bushings

### ■ Tank Type

Cast aluminum tank design

### ■ Tested Performance

Design tested to 10,000  
mechanical operations

### ■ Temperatures

-30°C without electrical heaters  
-50°C with electrical heaters



**HITACHI**  
Inspire the Next

**HVB**

# Specifications

HS Series	145kV 40kA	145kV 50kA	145kV 63kA	170kV 40kA
Voltage (kV)	145	145	145	170
BIL (kV crest)	650	650	650	750
60 Hz withstand (kV)	310	310	310	365
Continuous Current (A)	2000-3000-4000	2000-3000-4000	2000-3000-4000	2000-3000-4000
Interrupting Current (kA)	40	50	63	40
Interrupting time	3 cycles	2 - 3 cycles	2 - 3 cycles	3 cycles
Total weight (lbs)	7,000	11,905	10,600	7,000
Weight of SF6 Gas (lbs)	60	130	141	65
Pre-insertion resistor (Ohms)	150	N/A	N/A	N/A

Capacitance required

# Outline Drawing

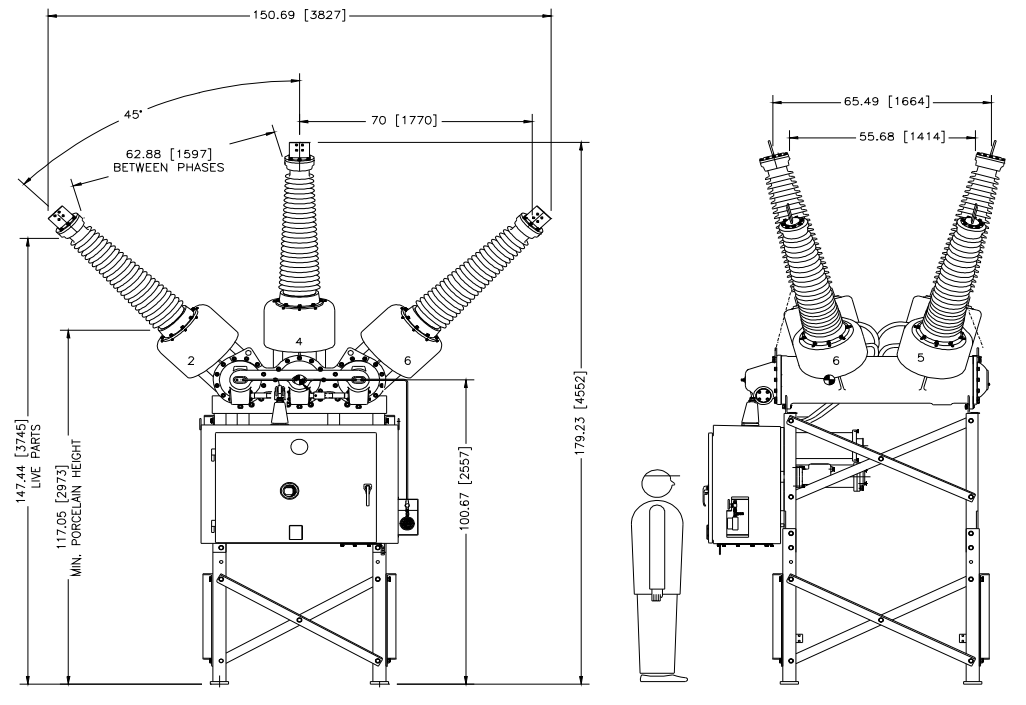

Outline drawing for information purposes only - Not to be used for construction

**HITACHI**  
Inspire the Next

Model Shown: 145kV 40kA

**HVB**

7250 McGinnis Ferry Road ♦ Suwanee, Georgia 30024

Phone: 770-495-1755 ♦ Fax: 770-623-9214 ♦ Toll Free: 866-362-0798